

REV	DESCRIPTION	DATE
0	ISSUE	11/14/05
1	Add lot trace label	07/23/08
2	Rev Mold size	04/19/12

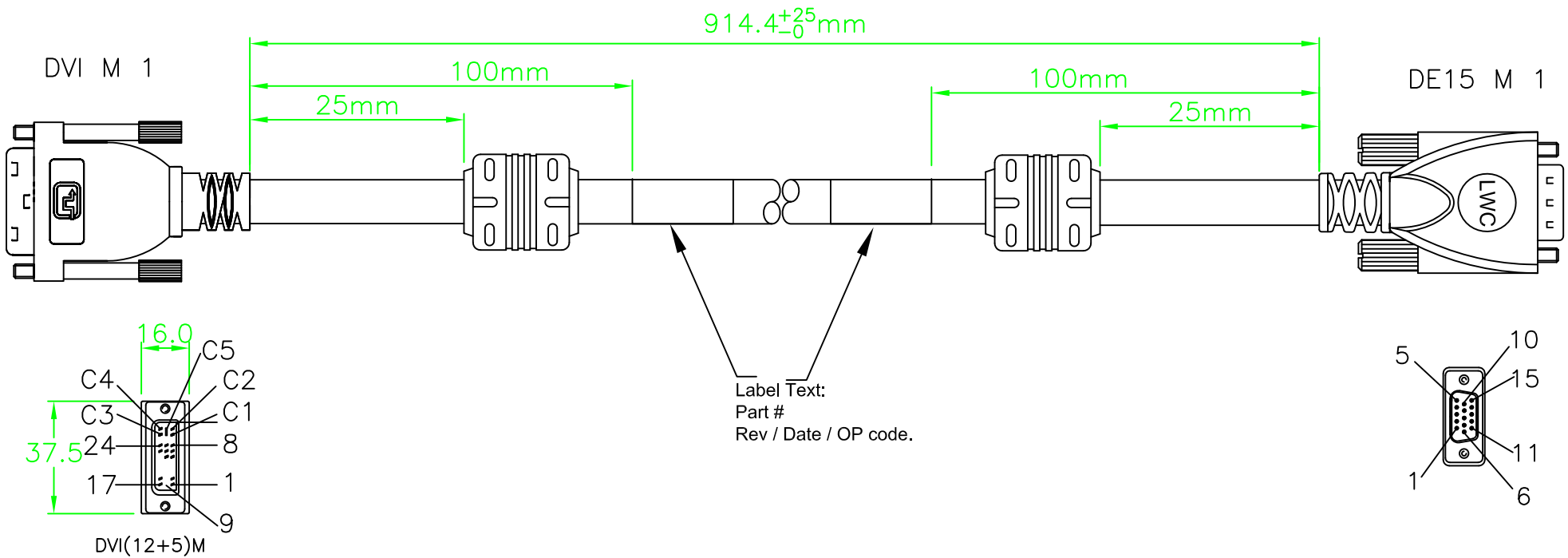

Notes:
 * Cable AWM 20276 rating
 * RoHS Compliant

E-DVI/A-VGAM-15	180	4
E-DVI/A-VGAM-6	72	2
E-DVI/A-VGAM-3	36	1
P/N.	L(in)	T(in)

LIBERTY AV SOLUTIONS
 11675 RIDGELINE DRIVE
 COLORADO SPRINGS, CO 80921

WWW.LIBAV.COM
 (800) 530-8998

UNIT:mm		TITLE:	
SCALE	None	Assembly Specification CBL, ASY, VGA, PVC	
UNLESS OTHERWISE SPECIFIED TOLERANCES: x ±.015 xx ±.010 xxx ±.005 ANGLE ± 1°		PART NUMBER:	DR. RP
		E-DVI/A-VGAM-XX	CH. RP
SHEET 1/2	DWG. #:	LWC-ASY-00664	AP. RP

REV	DESCRIPTION	DATE
0	ISSUE	11/14/05
1	Add lot trace label	07/23/08
2	Rev Mold size	04/19/12

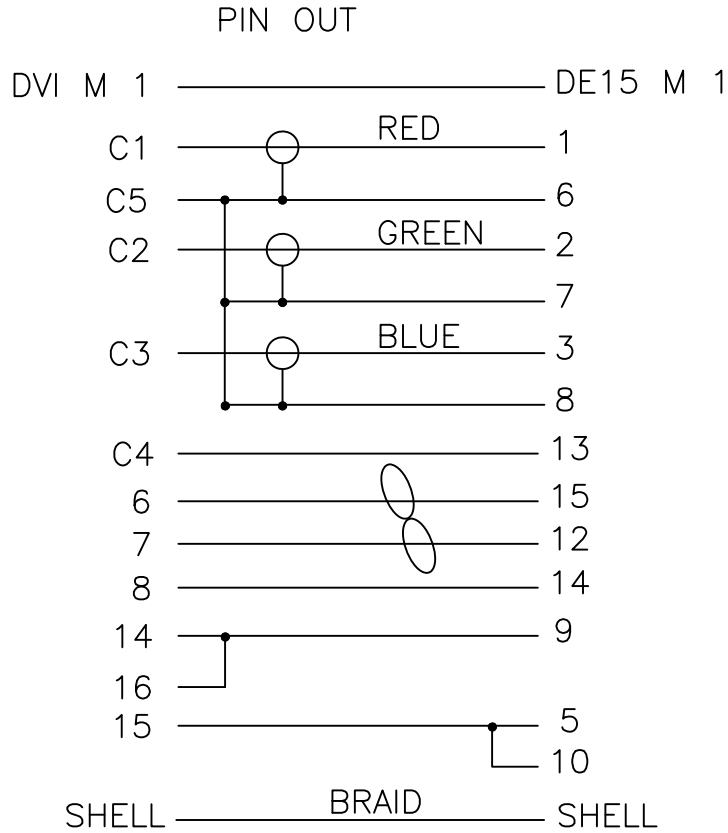

LIBERTY AV SOLUTIONS WWW.LIBAV.COM
 11675 RIDGELINE DRIVE (800) 530-8998
 COLORADO SPRINGS, CO 80921

	UNIT:mm	TITLE: Assembly Specification CBL, ASY, VGA, PVC	
SCALE	None		
UNLESS OTHERWISE SPECIFIED TOLERANCES: x ±.015 xx ±.010 xxx ±.005 ANGLE ± 1°		PART NUMBER:	DR. RP
		E-DVI/A-VGAM-XX	CH. RP
SHEET 2/2	DWG. #:	LWC-ASY-00664	AP. RP